

SERIES MTM-A

Magnetic translational measuring system - ABSOLUTE



The absolute MTM-A measuring system is based on the physical principle of magnetism and is used for a high-precision determination of the position, the moved distance and/or the speed. Based on this wear-free and contactless absolute measuring system, MTM-A is suitable for fixed round rod profiles, e. g. non-rotating piston rods of hydraulic cylinders in mobile automation tasks.



System consisting of:

- Round rod / piston rod (provided by the customer for coding by ELGO)
- Application related sensor (ELGO made)
- Mechanical accessories for sensor adaptation on request

Special features:

- Absolute position / path determination at round profile rods
- Wear-free, contactless measurement principle
- Very robust and proven measuring technology
- Insensitive to contamination
- High shock and vibration resistance
- Interface: Analog output or CANopen
- Power supply 10 ... 30 VDC

Technical Data:

Mechanical Data

Measurement principle	absolute
Repeat accuracy	± 1 increment
System accuracy	± 1 mm at max. 2500 mm measuring length (standard)
Distance sensor - round rod	1 mm
Round rod diameter	min. 20 mm
Measuring length	max. 2450 mm (available in 10 mm steps)
Material sensor head	aluminium, galvanized
Dimensions sensor head	L x B x H = 52 x 16 x 30 mm
Sensor cable length	standard: 1.5 m (others on request)
Weight sensor head	approx. 50 g without cable (cable: approx. 60 g/m)
Mounting position of MTM-A system	depends on application

Electrical Data

Power supply voltage	10 ... 30 VDC
Residual ripple	10 ... 30 VDC <10 %
Consumption	max. 80 mA
Available Interfaces	12 bit analog output (voltage)* 0.5 ... 4.5 V 12 bit analog output (current)* 4 ... 20 mA CANopen standard (DS406)
Connection type	Connection option 0: open cable ends Connection option 1: 8-pin M12 x 1 round connector on housing Connection option 2: 8-pin M12 x 1 round connector on signal cable
Maximum operating speed	up to 2.0 m/s

Environmental Conditions

Store temperature	-25 ... +85° C
Operating temperature	-25 ... +85° C
Humidity	max. 95 %, non-condensing
Protection class (entire system)	standard: IP65 / optionally: IP69K
Influence of external magnet on the coding of the round rod	External magnetic fields must not exceed 64 mT (640 Oe; 52 kA/m) on the coded round rod surface, as this can damage or destroy the round rod coding.

*) The analog output variant (voltage or current) can be specified with the order (see type designation on next page)

SERIES MTM-A

Magnetic translational measuring system - ABSOLUTE

Type designation:

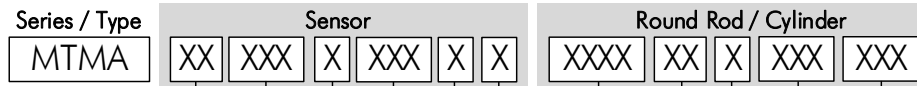

Version No.:

- 00 = standard version
- 01 = first special version

Cable length (max. 10.0 m):

- 015 = 1.5 m (standard)
- 072 = 7.2 m (example)

Sensor holder:

- O = without (holder provided by customer)
- H = holder as accessory part (on request)

Interface:

- 001 = Analog, voltage (0,5 ... 4,5 V)
- 002 = Analog, current (4 ... 20 mA)
- CA0 = CANopen standard (DS406)

Protection class:

- N = Standard IP65
- H = Heavy Duty IP69K

Connection options:

- 0 = open cable ends (standard)
- 1 = 8-pin round connector M12 x 1 on sensor housing
- 2 = 8-pin round connector M12 x 1 at signal cable

Measurement range in mm:

- 1000 = 1000 mm (example); up to max. 2500 mm possible; available in steps of 10 mm (e. g. 1010 mm)

System accuracy:

- 01 = 1 mm at max. 2500 mm measuring length (standard)

Width of single track coding:

- 1 = 10 mm
- 2 = 20 mm

Round rod diameter in mm:

- 050 = Ø 50 mm (example); minimum Ø = 20 mm
- Available Ø in mm: 25, 28, 32, 36, 40, 45, 50, 56, 63, 70, 80, 90, 100, 110, 125, 140, 160, 180, 200, 220, 250, 280, 320 und 360

Cylinder outer diameter in mm:

- 100 = Ø 100 mm (example); minimum Ø = 40 mm
- Available Ø in mm: 40, 50, 63, 80, 100, 110, 120, 125, 160, 200, 250, 320 and 400

Connections:

M12 x 1: 8 pin round connector

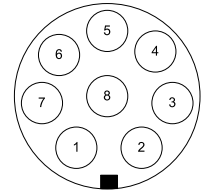

(socket, soldering side)

Pin assignment:

Pin	Color	Analog	CAN
1	black	0 V/GND	0 V/GND
2	brown	+VCC	+VCC
3	red	TEACH	n. c.
4	orange	-	n. c.
5	green	Analog OUT	CAN high
6	yellow	Analog GND	CAN low
7	n. c.	n. c.	n. c.
8	n. c.	n. c.	n. c.

With shielded versions, the shield is connected to the housing

Examples for customized sensor adaptations (can be realized by ELGO on request)

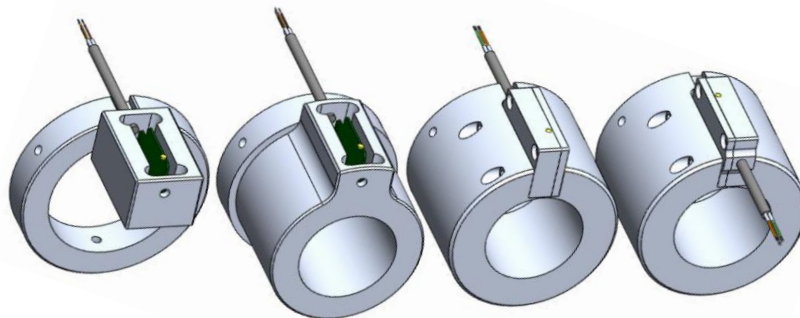

Integration example:

